



2016  
**OLIVARI** 

Dal 1911 Olivari realizza maniglie in Italia,  
all'interno dei propri stabilimenti,  
dove si svolge l'intero ciclo produttivo.  
Partendo da barre in ottone, le maniglie vengono  
stampate, lavorate, smerigliate, lucidate,  
cromate e marchiate al laser.

Olivari ha ottenuto le certificazioni  
ISO 9001 e ISO 14001  
e si avvale delle tecnologie più evolute,  
ma ha mantenuto tutta la sapienza artigianale  
accumulata in cento anni di storia.

Since 1911 Olivari has been manufacturing handles  
at its own factories in Italy  
where the entire production process takes place.

Starting with brass billets, the handles are forged, milled,  
polished, buffed, chrome-plated and hallmarked with a laser.  
Olivari has attained ISO 9001  
and ISO 14001 certifications.

Though it uses the most advanced technology,  
Olivari preserves all the artisanal wisdom  
it has accumulated in 100 years of history.

**OLIVARI** 

Rem Koolhaas  
Zaha Hadid  
Marcel Wanders  
architecture stars  
for cosmic handles



# Open

OMA/Rem Koolhaas 2015

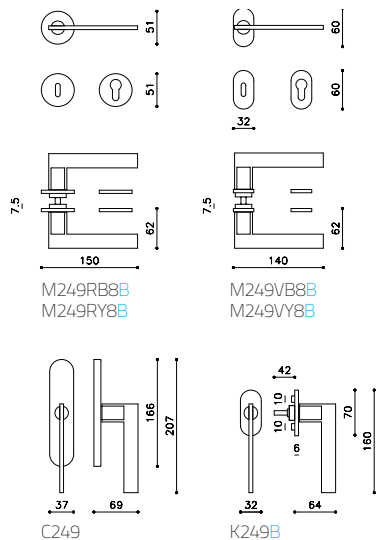

M249RB8B  
M249RY8B

M249VB8B  
M249VY8B

C249

K249B



CA cromato-cromato opaco  
chrome-mat chrome



CR cromato/chrome



CO cromato opaco/mat chrome



IS superinox satinato  
superstainlesssteel satin



US superantracite satinato  
superanthracite satin

*Open è il risultato di un processo di riduzione della maniglia alle sue componenti funzionali elementari: il mozzo e la leva. Questa separazione modulare ha come risultato due elementi indipendenti che, unendosi meccanicamente, generano molteplici combinazioni di metalli e finiture. Open ricorda un utensile meccanico. La semplicità formale dell'impugnatura esalta le qualità del metallo e si presta ad ulteriori variazioni: forature e sottrazioni aprono inoltre a nuove possibilità di utilizzo quotidiano. Open è realizzata in ottone nelle finiture cromo, cromo opaco, superinox satinato e superantracite satinato.*

*Open is the result of a process of reducing the handle to the primary functional components: the hub and the lever. This modular separation results in two independent elements that join mechanically to generate multiple combinations of metals and finishes. Open resembles a mechanical tool: the simplicity of its 'formal grip' enhances the quality of the metal, and lends itself to further variations: punctures and subtractions open new possibilities for everyday use. Open is available in three finishes: chrome, mat chrome, superinox satin and superanthracite satin.*















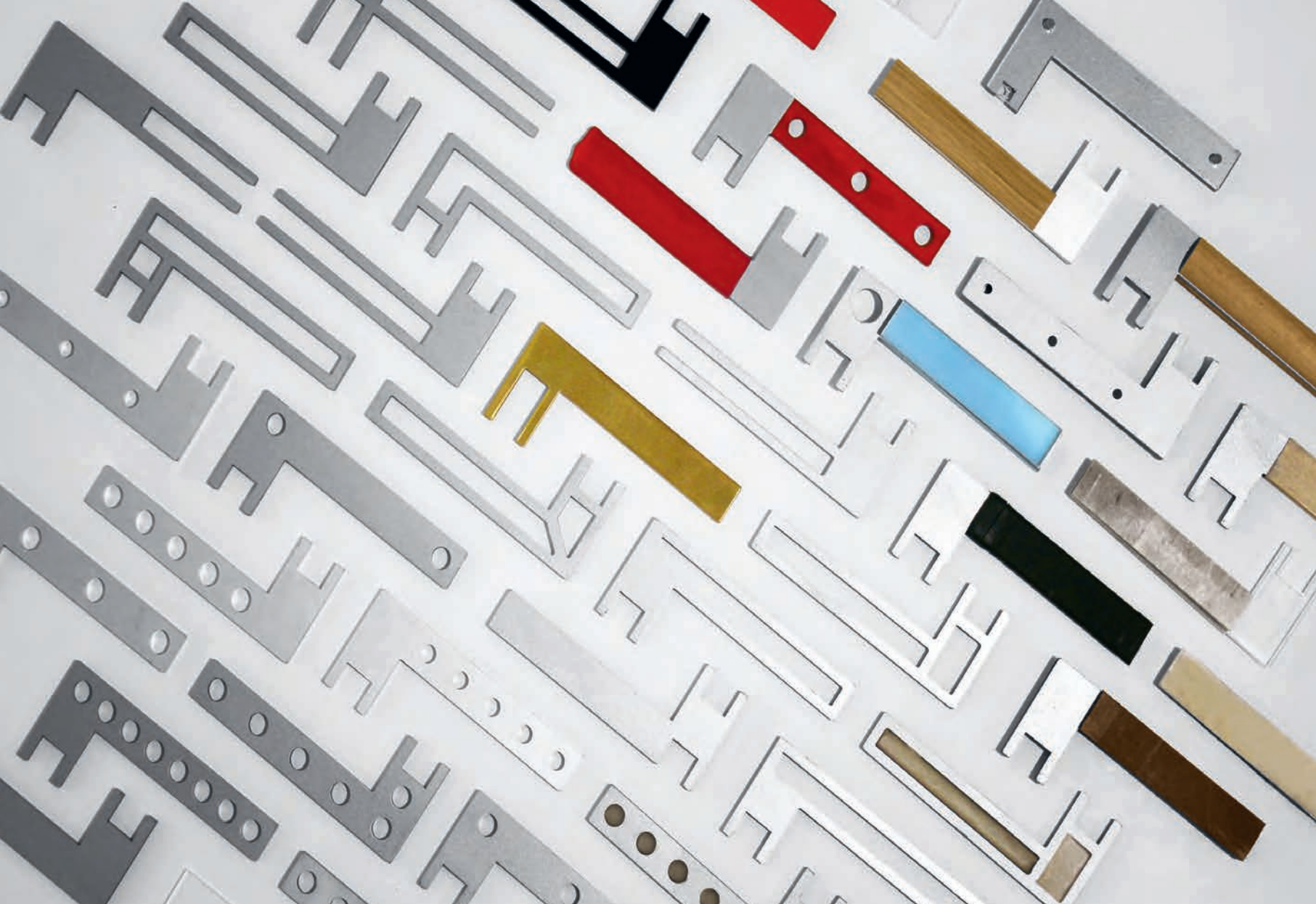









# OMA/Rem Koolhaas

Rotterdam, 1944

*Rem Koolhaas () ha fondato OMA nel 1975 insieme a Elia e Zoe Zenghelis e Madelon Vriesendorp. Si è laureato presso l'Architectural Association di Londra e nel 1978 ha pubblicato Delirious New York: Un manifesto retroattivo di Manhattan. Nel 1995, il suo libro S, M, L, XL ha riassunto il lavoro di OMA in "un romanzo sull'architettura". Dirige il lavoro di entrambi OMA e AMO, il ramo di ricerca di OMA, operanti in zone al di fuori del regno dell'architettura come i media, la politica, le energie rinnovabili e la moda. Koolhaas ha vinto diversi premi internazionali tra cui il Pritzker Architecture Prize nel 2000, il Praemium Imperiale, nel 2003, il Leone d'oro alla carriera alla Biennale di Venezia del 2010, il RIBA Award Charles Jencks nel 2012, e la Johannes Vermeer Prijs nel 2013. Koolhaas è professore all'Università di Harvard dove dirige il Progetto sulla città. Nel 2014, ha diretto la 14 ° Mostra Internazionale di Architettura della Biennale di Venezia, dal titolo Fundamentals.*

*Rem Koolhaas founded OMA in 1975 together with Elia and Zoe Zenghelis and Madelon Vriesendorp. He graduated from the Architectural Association in London and in 1978 published Delirious New York: A Retroactive Manifesto for Manhattan. In 1995, his book S,M,L,XL summarized the work of OMA in "a novel about architecture". He heads the work of both OMA and AMO, the research branch of OMA, operating in areas beyond the realm of architecture such as media, politics, renewable energy and fashion. Koolhaas has won several international awards including the Pritzker Architecture Prize in 2000, the Praemium Imperiale in 2003, the Golden Lion for Lifetime Achievement at the 2010 Venice Biennale, the RIBA Charles Jencks Award in 2012, and the Johannes Vermeer Prijs in 2013. Koolhaas is a professor at Harvard University where he conducts the Project on the City. In 2014, he directed the 14th International Architecture Exhibition of the Venice Biennale, entitled Fundamentals*

1\_CCTV television station and headquarters, Beijing, China, Ph. Iwan Baan.

2\_Fondazione Prada, Fondazione Prada, Ph. Bas Princen.

3\_Seattle Central Library, Seattle, USA, Ph. Philippe Ruault.

4\_Timmerhuis, Rotterdam, Netherlands, Ph. Ossip van Duivenbode.



# Chevron

design Zaha Hadid 2015

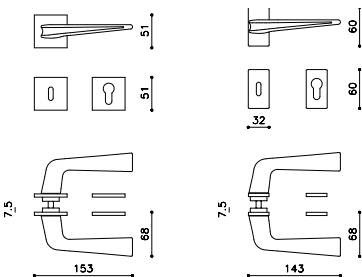

M248RB8B  
M248RY8B

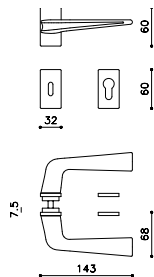

M248VB8B  
M248VY8B

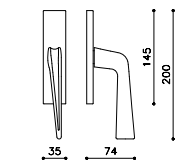

C248

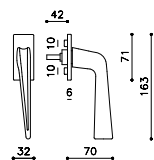

K248B

  
ottone/brass



CR cromato/chrome



CO cromato opaco/mat chrome



US superanthracite satinato  
superanthracite satin



Per Chevron Zaha Hadid trae ispirazione dal suo primo progetto a New York City, un edificio residenziale situato accanto a High Line Park. La maniglia ricorda infatti l'elemento scultoreo che caratterizza la facciata del palazzo. Il design, una forma vigorosa accentuata da curve morbide, segue la stessa ricerca sperimentale della struttura dinamica ed innovativa tipica di ogni progetto di Hadid. Chiaramente riconducibile agli elementi di architettura in sviluppo orizzontale e di simmetria dell'edificio di New York, il corpo della maniglia prende una potente forma ricurva, che migliora l'ergonomica relazione tra la mano e l'oggetto, ottimizzandola attraverso una serie di intagli delicati. Chevron è realizzata in ottone nelle finiture cromo, cromo opaco e superanthracite satinato.

Inspired by Zaha Hadid's first project in New York City, a residential building located beside High Line Park, the door handle is informed by the chevron pattern of the apartment block's façade. The design, a strong form accentuated by delicate curves, follows the same experimental framework that each of Hadid's dynamic and innovative project has been built on. Extracted from architectural elements of horizontality and symmetry of the New York building, the handle's body takes upon a powerful, curving form, which enhances the ergonomic relationship between the hand and the item, optimizing it through a series of delicate carving-out of the object's volume. Chevron is available in three finishes: chrome, mat chrome and superanthracite satin.

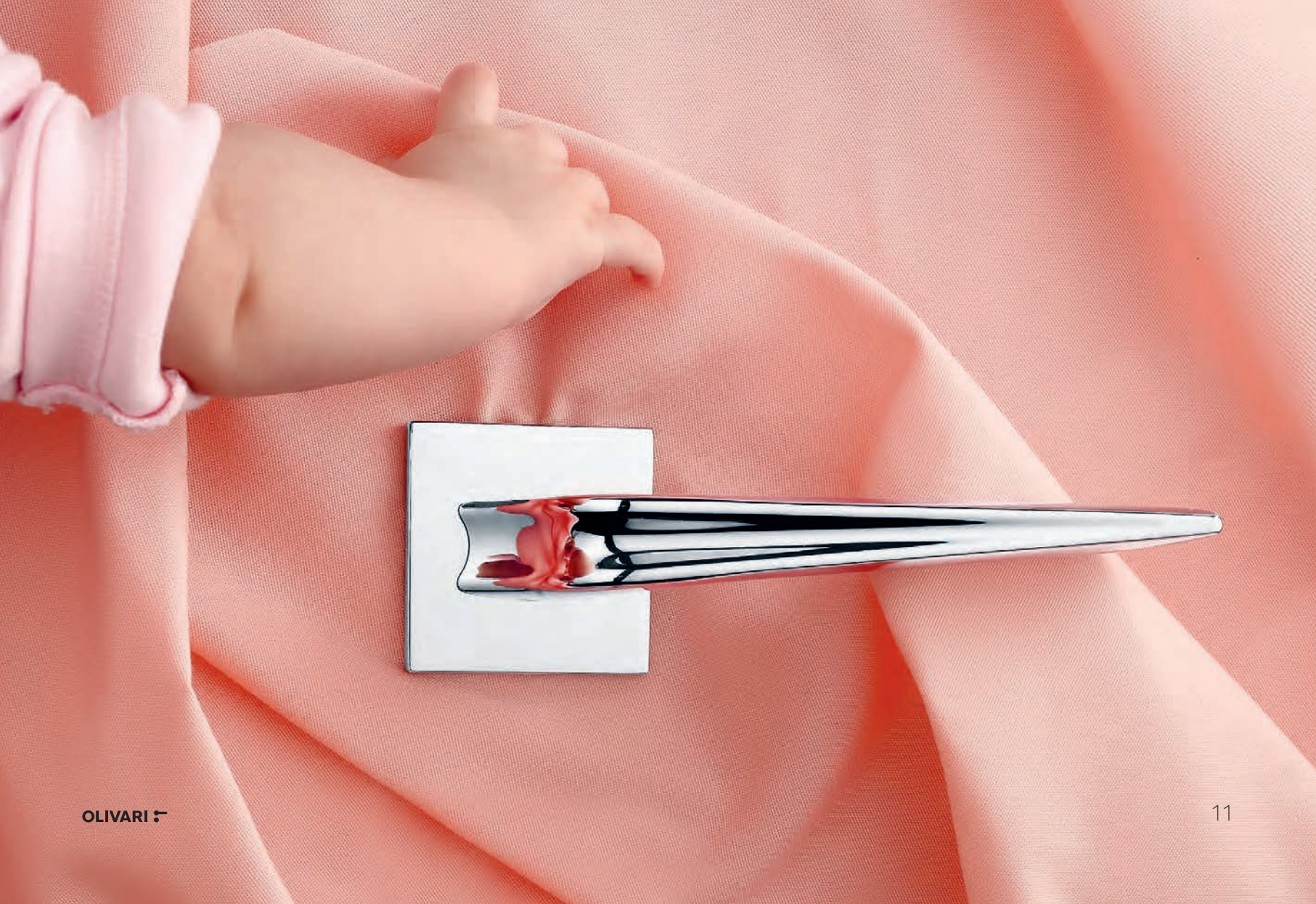















# Zaha Hadid

*Zaha Hadid, fondatrice di Zaha Hadid Architects (ZHA), è stata insignita del Pritzker Architecture Prize nel 2004. Ciascuno dei suoi progetti pionieristici si basa su oltre trenta anni di esplorazione e di ricerca nei settori interconnessi dell'urbanistica, dell'architettura e del design. Hadid ha tenuto numerose cattedre nelle università di tutto il mondo, tra cui Columbia, Harvard e Yale; è attualmente professoressa presso l'Università di Arti Applicate di Vienna. L'opera di Hadid integra topografia naturale e sistemi creati dall'uomo, che portano all'innovazione con le nuove tecnologie e costantemente spinge i confini di architettura e design.*

*Zaha Hadid, founder of Zaha Hadid Architects (ZHA), was awarded the Pritzker Architecture Prize in 2004. Each of her pioneering projects builds on over thirty years of exploration and research in the interrelated fields of urbanism, architecture and design. Hadid has held numerous chairs and guest professorships at universities around the world including Columbia, Harvard and Yale; she is currently a professor at the University of Applied Arts in Vienna. Hadid's work integrates natural topography and human-made systems, leading to innovation with new technologies and consistently pushing the boundaries of architecture and design.*

1\_ 520 W 28 Street New York, Detail,  
Ph. Zaha Hadid Architects.  
2\_ Heydar Aliyev Centre Baku, Exterior,  
Ph. Hufton+Crow.  
3\_ London Aquatics Centre, Exterior,  
Ph. Hufton+Crow.  
4\_ MAXXI National Museum of XXI  
Century Arts Rome\_ Interior,  
Ph. Helene Binet.



# Crystal

design Marcel Wanders 2015

## Crystal Royal

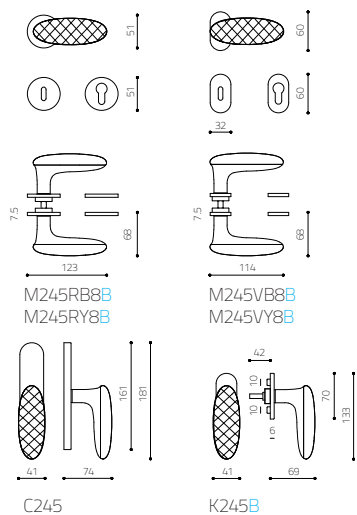

 ottone e vetro/brass and glass

## Crystal Diamond

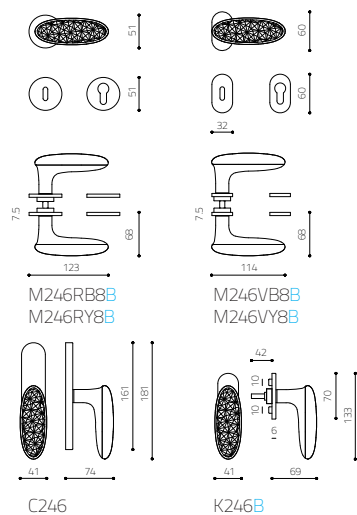

 ottone e vetro/brass and glass





Crystal Royal









Crystal Diamond







*La collezione di maniglie Crystal del 2015 di Marcel Wanders per Olivari è una sorta di compendio della storia e dell'abilità artigianale, maturata dall'azienda in oltre 100 anni di vita.*

*È una luminosa e scintillante continuità della combinazione di minimalismo e classicismo evocati dalla sua maniglia "Dolce Vita" (2014). Divisa in due parti, una in ottone e l'altra, frontale, in cristallo, ci consente d'intravedere – attraverso il cristallo – il decoro riflesso sull'ottone.*

*È il prezioso gioiello della porta, che è un piacere osservare e tenere in mano nell'atto di passare oltre, verso un interno pieno di sorprese. Crystal è un tocco decorativo e raffinato che ridefinisce l'immagine stessa di una porta. La collezione Crystal è disponibile in tre finiture: cromo, superoro e superantracite satinato, e con due tipologie di cristallo: 'Royal' e 'Diamond'.*

*Marcel Wanders 2015 handle collection for Olivari expands the company's 100 years of accumulated history and artisanal wisdom. The new Crystal collection offers a dazzling continuation of the combination of minimalism and classicism evoked by the 'Dolce Vita' (2014) handle.*

*The new Crystal handle is divided into one half brass and one half of crystal glass. This allows a glimpse of the decoration on the brass behind the crystal. It is the precious jewel of the door. A gem to hold that grants passage into an awaiting interior full of surprises. Crystal is a decorative and elegant touch that redefines the very image of a door. The Crystal collection is available in three finishes: chrome, supergold and superanthracite satin finish. The crystal is also available in two different styles, namely a 'Royal' and 'Diamond' cut.*

Crystal Royal



C6 cromato/chrome



M6 cromato opaco/mat chrome



Z6 superoro lucido/supergold bright



U6 super antracite satinato  
super anthracite satin

Crystal Diamond



C6 cromato/chrome



M6 cromato opaco/mat chrome



Z6 superoro lucido/supergold bright



U6 super antracite satinato  
super anthracite satin



Flos, Zeppelin, 2005

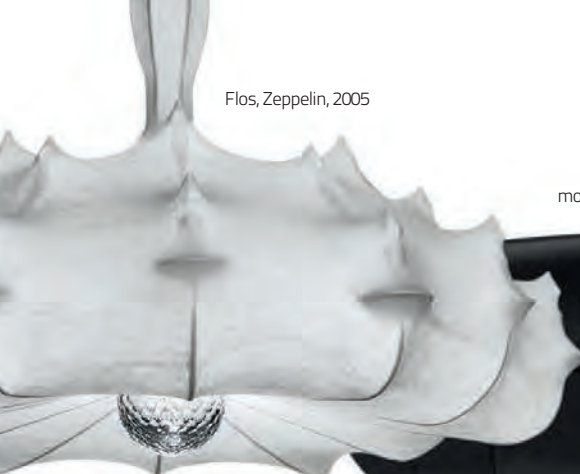

moooi\_containerbowl



Moooi\_lighting collection Double Round light



Moooi Parent Chair



love\_chair moooi



Knotted chair, 1996



## Marcel Wanders

Boxtel, 1963

*Considerato da molti come un'anomalia nel mondo del design, Marcel ha fatto del suo lavoro una missione, "creare un ambiente di amore, vivere con passione, e rendere i nostri sogni più emozionanti". I suoi lavori eccitano, provocano, e polarizzano, e non mancano mai a sorprendere per la loro ingenuità, audacia, come singolare tentativo di elevare lo spirito umano, e intrattenere. La principale preoccupazione di Marcel è quella di portare il tocco umano di nuovo al design, inaugurando quello che lui chiama di design 'new age,' in cui designer, artigiani e utilizzatori finali si ricongiungono. Nel suo processo, Marcel definisce il suo dogma di progettazione, preferendo, invece che concentrarsi su soluzioni olistiche, la tecnocrazia. Nell'universo di Marcel, la freddezza dell'industrialismo è sostituita invece dalla poesia, fantasia e romanticismo di età diverse, vividamente portato alla vita nel momento contemporaneo.*

*Regarded by many as an anomaly in the design world, Marcel has made his mission to "create an environment of love, live with passion and make our most exciting dreams come true." His work excites, provokes, and polarizes, but never fails to surprise for its ingenuity, daring and singular quest to uplift the human spirit, and entertain.*

*Marcel's chief concern is bringing the human touch back to design, ushering in what he calls design's 'new age;' in which designer, craftsperson and user are reunited. In his process, Marcel defies design dogma, preferring instead to focus on holistic, technocratic solutions. In Marcel's universe, the coldness of industrialism is replaced instead by the poetry, fantasy and the romance of different ages, vividly brought to life in the contemporary moment.*



superantracite satinato **superantracite satiné**



Aurelia



Beta



Bios



Blindo



Chevron



Conca



Diamond



Diana



Dolcevita



Euclide Q



Euclide



Lama



Link



Living



Lotus Q



Lotus



Lucy



Nina



Open



Planet QB



Planet Q



Planet B



Planet



Radial



Raffaella



Royal



Total



Trend



Twist

Il catalogo ed i prodotti sono soggetti ad aggiornamenti.  
Modelli e marchi depositati.  
Tutti i diritti riservati © Olivari B. s.p.a.  
Catalog and products subject to updating.  
Registered trademarks and patented designs.  
All rights reserved © Olivari B. s.p.a.

#### Concept and graphic

Marco Strina

#### Photo

Bruno Pulici, Alessandro Di Giugno, BHM studio, Sauro Sorana

#### Press Office

Clara Buoncristiani

#### Pre press

Up studio\_Milano

#### Printed in Italy

Grafiche Fovana & Caccia s.r.l.

#### thanks to

OMA/Rem Koolhaas studio

Zaha Hadid studio

Marcel Wanders studio

#### Olivari B. spa

Via Giacomo Matteotti, 140  
28021 Borgomanero NO Italy

T +39 0322 835080

F +39 0322 846484

olivari@olivari.it

www.olivari.it







[olivari.it](http://olivari.it)